

# LWBE-190 Series

## Product Characteristic

- Impeller Material: PA6+GF
- Supply Voltage: 230V,50/60Hz
- Mode Of Operation: S1
- Protection Class: IP55
- Insulation Class: F
- Operation Temperature: -25°C ~ +60°C
- Technical Feature: Control input 0-10VDC/PWM, Tech output, Locked-Rotor protection, Reverse Polarity Over-voltage protection, Soft Start Protection.



## Technical Specifications

| Model              | Voltage (V) | Input Power (W) | Current (A) | Air Volume (m³/h) | Static Pressure (Pa) | Speed (RPM) | Noise [dB(A)] |
|--------------------|-------------|-----------------|-------------|-------------------|----------------------|-------------|---------------|
| LWBE3G190-072PS-06 | 230         | 64              | 0.53        | 639               | 453                  | 2940        | 65            |

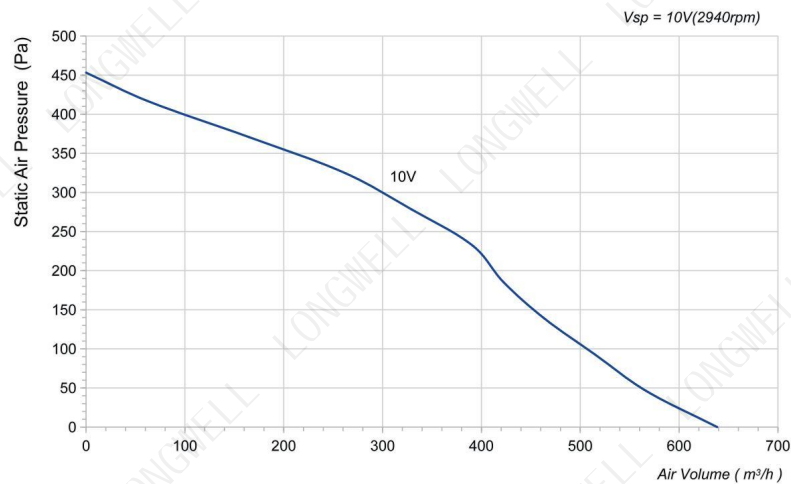

## LWBE3G190-072NS-14 (without bracket)

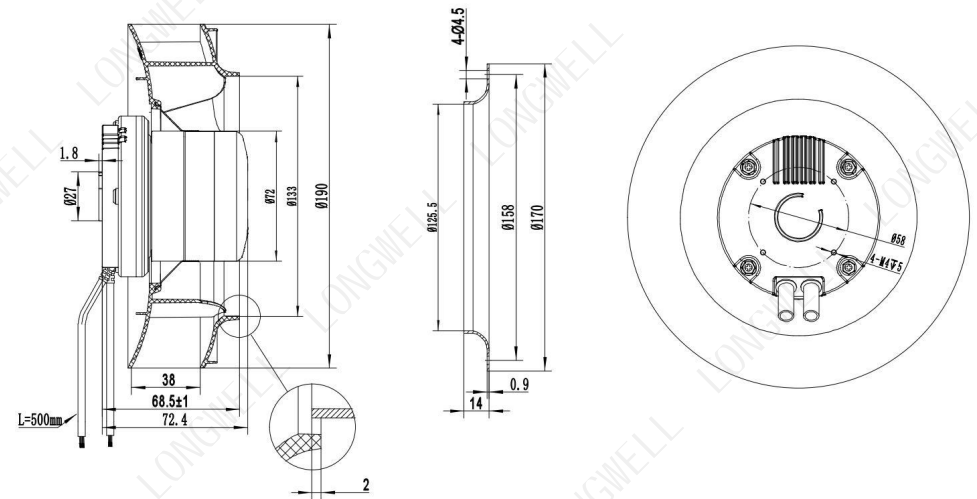

## LWBE3G190-072PS-06 (with bracket)

