

LWAE-450 Series

Product Characteristic

- Material: Sheet steel
- Type of protection: IP54
- Insulation class: B
- Approvals: CCC CE
- Motor type: BLEC motor
- Perm. amb.temp.: -25 C ~ +60 C
- Technicial Feature: Control input 0-10VDC/PWM, Tech output, Locked-Rotor protection, Reverse Polarity Over-voltage protection Soft Start Protection.



Technical Specifications

Model	Voltage	Frequency	Current	Power	Speed	Air Volume	Static Pressure	Noise	Curve
	V	Hz	A	W	RPM	m³/h	Pa	dB(A)	
LWAE3G450SS-5MNW-01	220	50/60	2.0	420	1590	6500	240	68	①
LWAE3G450ST-5MNW-02	220	50/60	2.0	420	1590	6500	240	68	
LWAE3G450SS-5MEW-03	220	50/60	2.0	420	1590	6500	240	68	
LWAE3G450ST-5MEW-04	220	50/60	2.0	420	1590	6500	240	68	
LWAE3G450SS-5MGW-05	220	50/60	2.0	420	1590	6500	240	68	
LWAE3G450ST-5MGW-06	220	50/60	2.0	420	1590	6500	240	68	

Flow Rate Curve

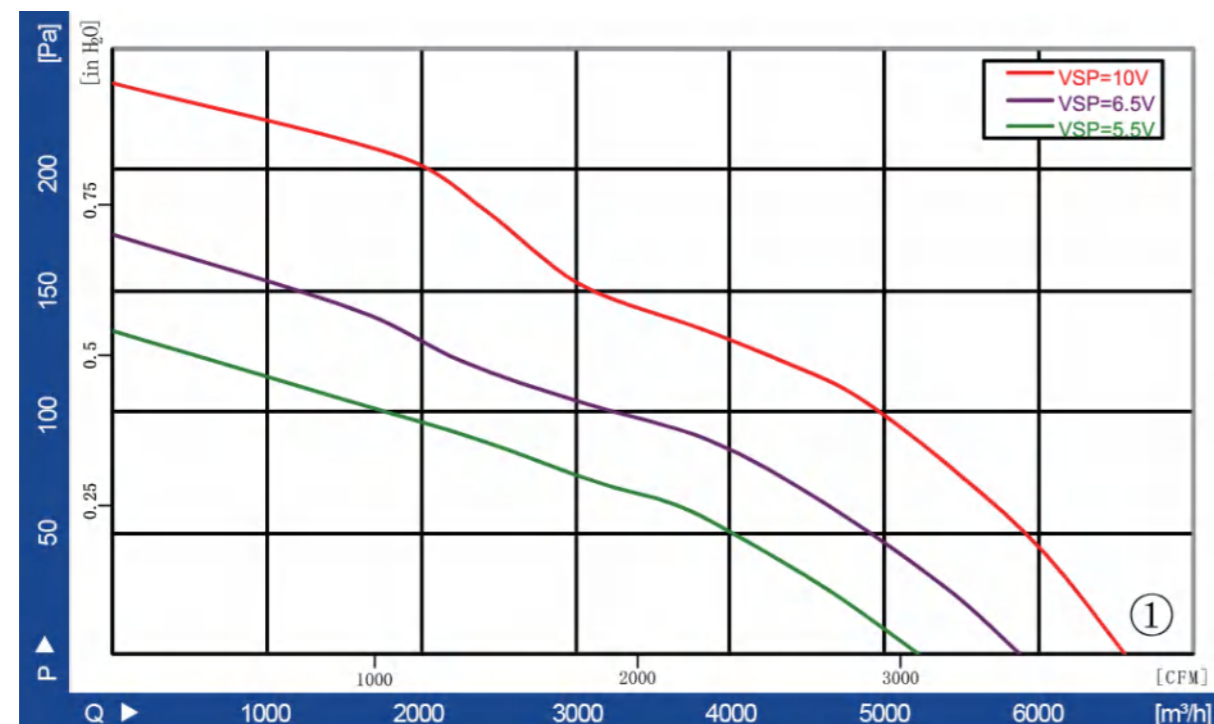

Product Drawing

LWAE3G450SS-5MNW-01(Suction)

LWAE3G450ST-5MNW-02(Blowing)

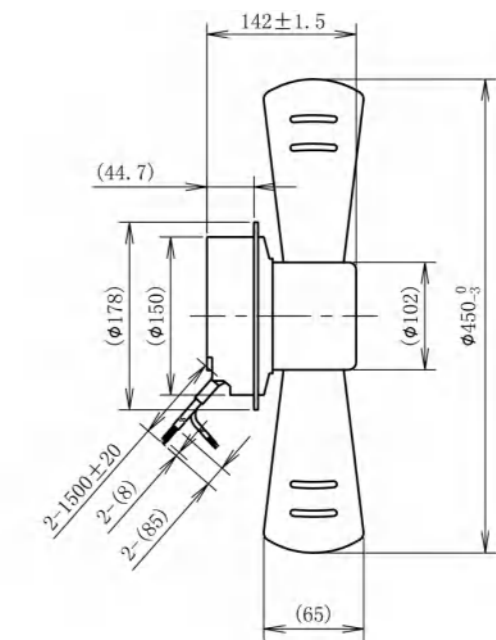
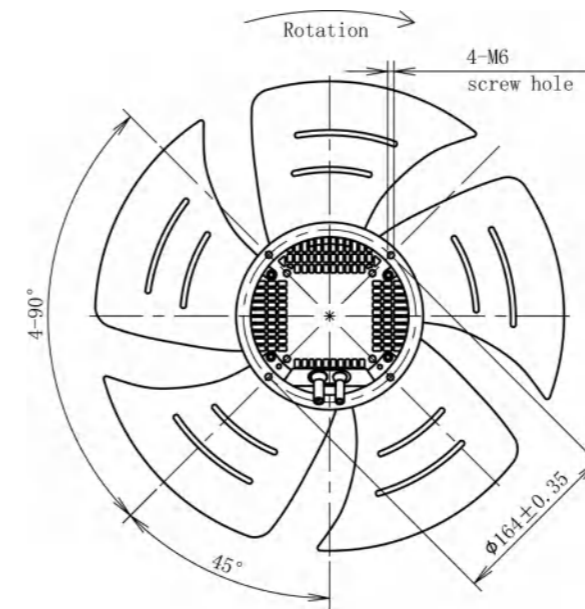

LWAE3G450SS-5MEW-03(Suction)

LWAE3G450ST-5MEW-04(Blowing)

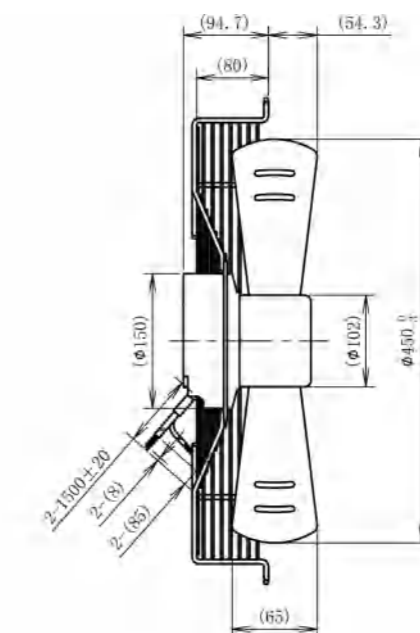
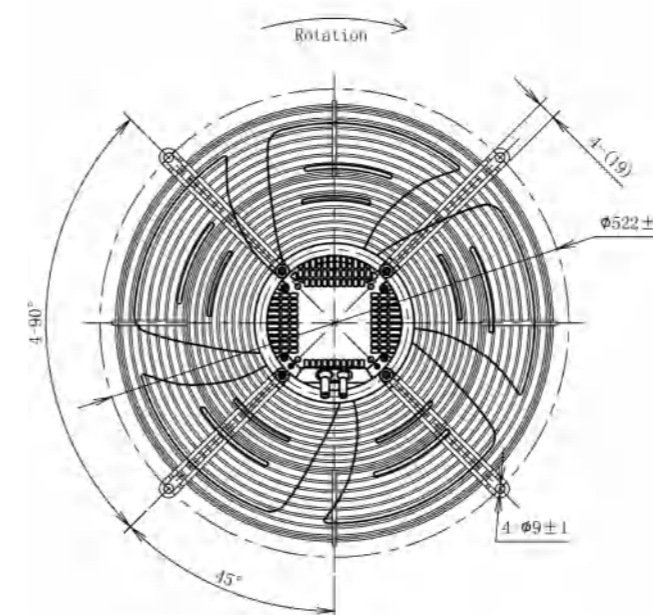

With wall concave net cover grill

LWAE3G450SS-5MGW-05(Suction)

LWAE3G450ST-5MGW-06(Blowing)

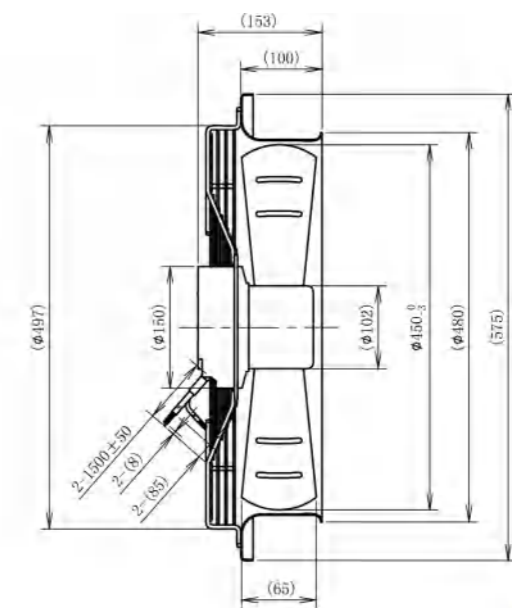
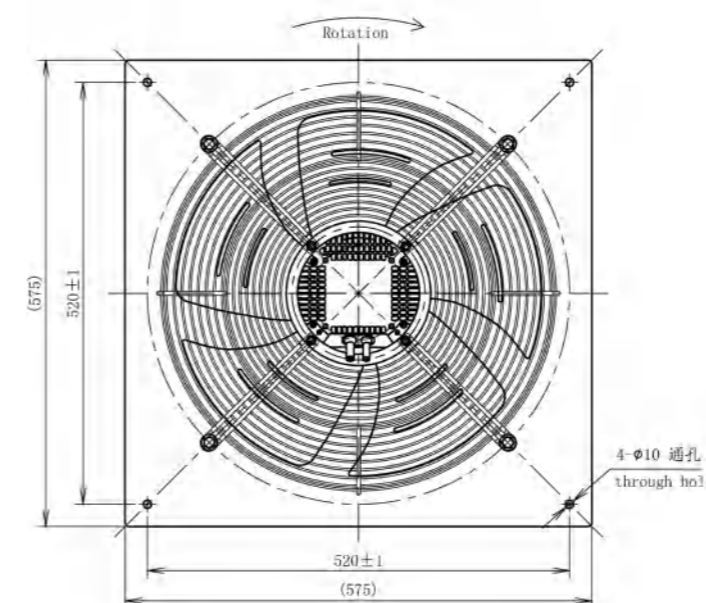

With wind guide panel