

LWAA-350 Series

Product Characteristic

- Blades : Cold rolled steel
- Number of blades: 5
- Mode of operation: S1
- Type of protection: IP55
- Insulation class: F
- Operation Temperature: -30~+60 C



Technical Specifications

Model	Voltage (V)	Frequency (Hz)	Current (A)	Power (W)	Speed (RPM)	Air Volume (m³/h)	Capacitor (uF)	Noise [dB(A)]	Curve
LWAA4E350S-5MKB-13	220/230	50	0.58	155	1350	3348	3	55	①
LWAA4E350S-5MKB-14	220/230	60	0.8	200	1500	3760	3	58	②
LWAA4D350S-5MKB-15	380/400	50	0.42	155	1350	3348	/	55	①
LWAA4D350S-5MKB-16	380/400	60	0.47	200	1500	3760	/	58	②

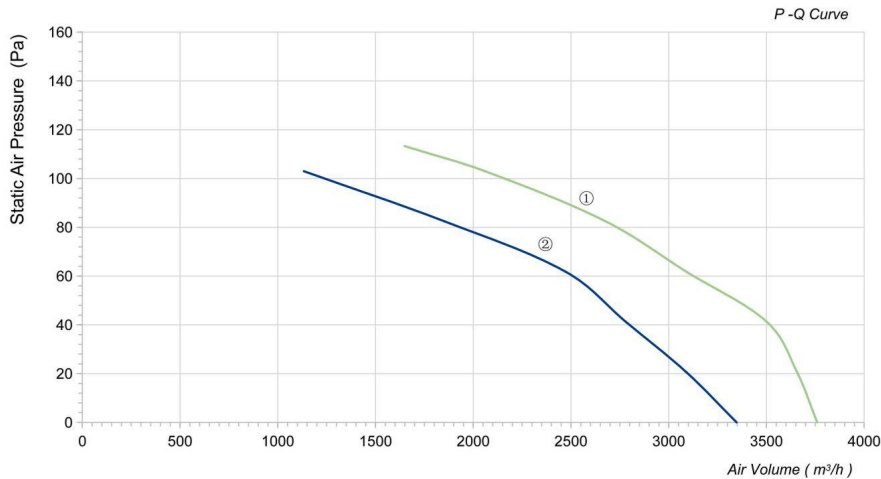

Product Drawing (mm)

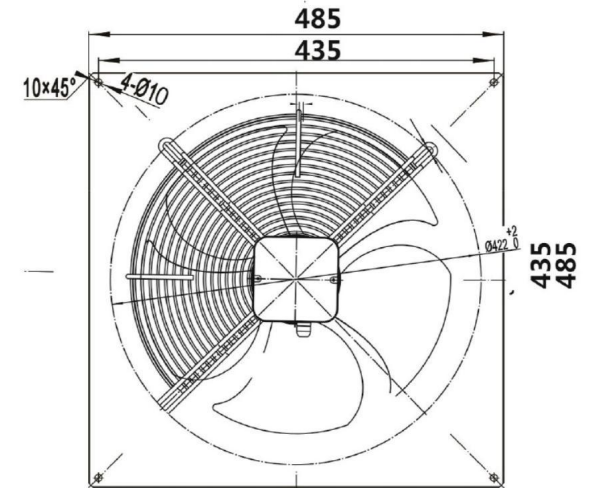
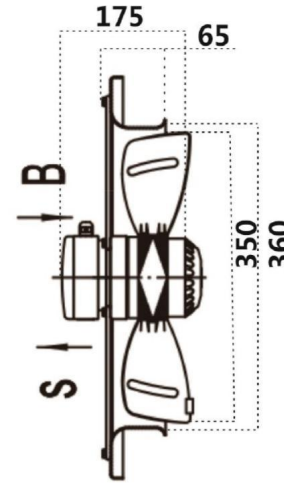

Section
Direction of airflow "S"